



BIOMASS TORREFACTION: TECHNOLOGICAL SERVICES

Torrefaction is a thermochemical treatment of the biomass, carried out at temperatures between 200 and 300° C in the absence of O₂. This treatment produces beneficial changes on the biomass fuel, such as the improvement in milling behavior, the increase of calorific value, reduction of Cl, N and S content, reduction of equilibrium moisture content and the improved resistance to biological degradation.

Torrefaction is a viable technological solution for obtaining high quality fuels from biomass residues. CENER has over 10 years of experience in torrefaction projects and in the operation of the pilot plant, with a broad range of feedstocks.

In order to warranty the successful development of customer´s project, CENER offers the following technological services with an integral accompaniment during the whole project life cycle:

- Characterization of the torrefaction behavior of customer´s specific biomass
- Torrefaction test in CENER's pilot plant with customer´s specific biomass
- Techno-economical feasibility study, process design assessment and optimization
- Project engineering
- Plant commissioning

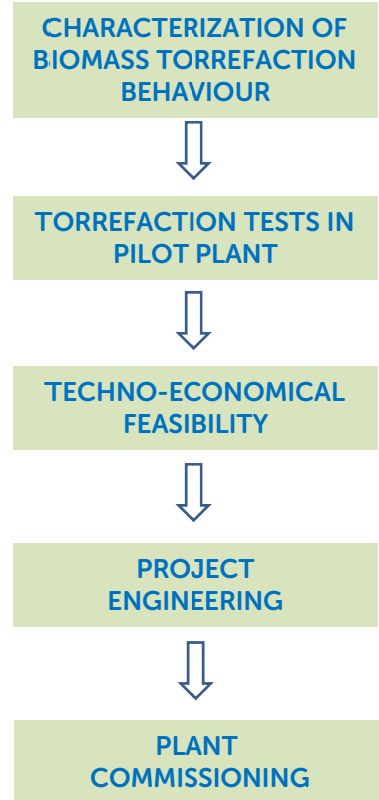

Characterization of Biomass Torrefaction Behaviour

CENER has developed its own methodology to characterize the torrefaction behavior of customer´s specific biomass. The methodology allows for quantitative prediction of the torrefaction behavior, the selection of optimal conditions for pilot testing and pilot test results upscaling by means of the modellization of the torrefaction process.

The methodology consists of:

- Characterization of physical properties for the calculation of the heat transfer coefficient and residence time inside the reactor
- Thermogravimetric analysis (TGA) for kinetic parameters calculation
- Differential scanning calorimetry (DSC) to calculate heat of reaction during torrefaction and asses selfheating behavior of the torrefied product

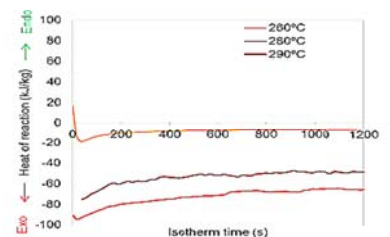
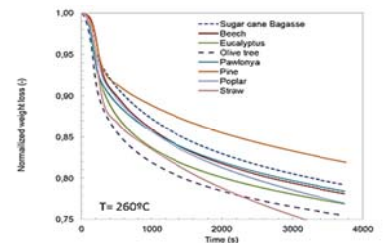



BIOMASS ENERGY

Torrefaction Test in Pilot Plant

CENER has a Torrefaction Pilot Plant with a production capacity from 150 to 350 kg/h, depending on feedstock characteristics and product specification. The core of the process equipment is the torrefaction reactor of special design manufactured by LIST TECHNOLOGY AG.

Torrefaction process should be adapted to specific raw materials and to specific final product specifications. Investment and O&M costs should be optimized for each torrefaction project.

The capacity and characteristics of the Pilot plant allows for:

- Defining and optimizing process operation conditions to fulfill product specification
- Production of batches for product validation
- Production Cost Optimization and Technical and Economic Feasibility Analysis Validation
- Measuring process yields and energy consumption to develop mass and energy balances for the basic engineering of the industrial torrefaction plant
- Generating the data for direct reactor scale up to industrial scale production



Techno-Economical Feasibility Studies

CENER has developed its own Methodology for the elaboration of Technical and Economic Feasibility Studies of torrefaction projects. The methodology is based on the characterization of the torrefaction behavior of the biomass and the use of different models developed by CENER:

- Torrefaction reactor model including:
 - Solid flow model
 - Heat transfer model
 - Torrefaction kinetic model
 - Heat of reaction model
- Integrated Mass and Energy Balance Model
- Torrefied product composition model
- Production cost economical model

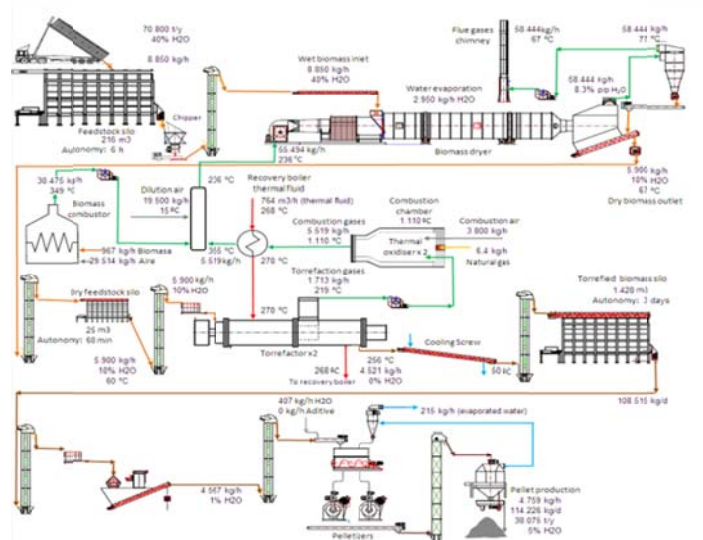
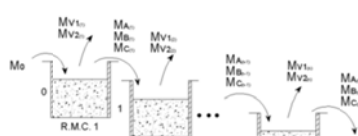
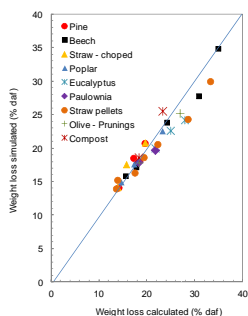



CENER
ADItch

CENTRO NACIONAL DE
ENERGIAS RENOVABLES
NATIONAL RENEWABLE
ENERGY CENTRE



BIOMASS ENERGY

Project Engineering

CENER has experience in torrefaction projects for more than 10 years. Based on the experience of CENER in the construction of the pilot plant and the operational experience with a broad range of feedstocks, CENER will assist customer's project engineering in order to:

- Define process configuration/integration
- Develop equipment specifications and plant layout
- Develop safety measures
- Develop mass and energy balances
- Make equipment selection
- Develop process operation and control philosophy

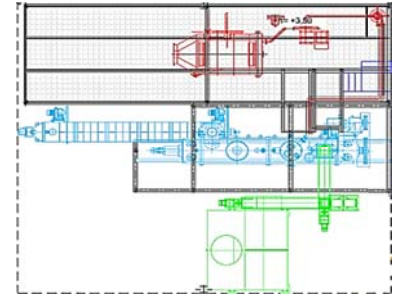
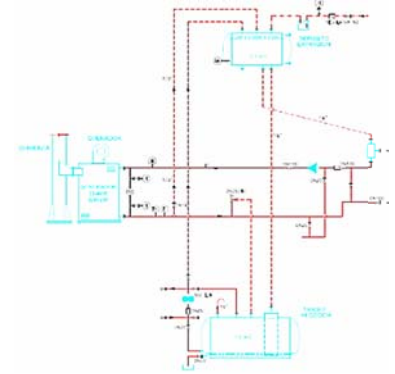

Plant Commissioning

Based on CENER's experience in the commissioning and operation of the pilot plant, CENER will accompany customers in order to:

- Develop work procedures
- Develop quality assurance procedures
- Define plant laboratory equipment
- Set up analysis laboratory methods
- Train plant operators and laboratory personnel



Additional Services

CENER also provides the following services:

- Characterization of Solid Biofuels
- Development of torrefied materials Pelletization process
- Sustainability and Life Cycle Analysis



MINISTERIO DE ENERGÍA, TURISMO Y AGENDA DIGITAL

MINISTERIO DE ECONOMÍA, INDUSTRIA Y COMPETITIVIDAD

Ciemat

